

BRAKE

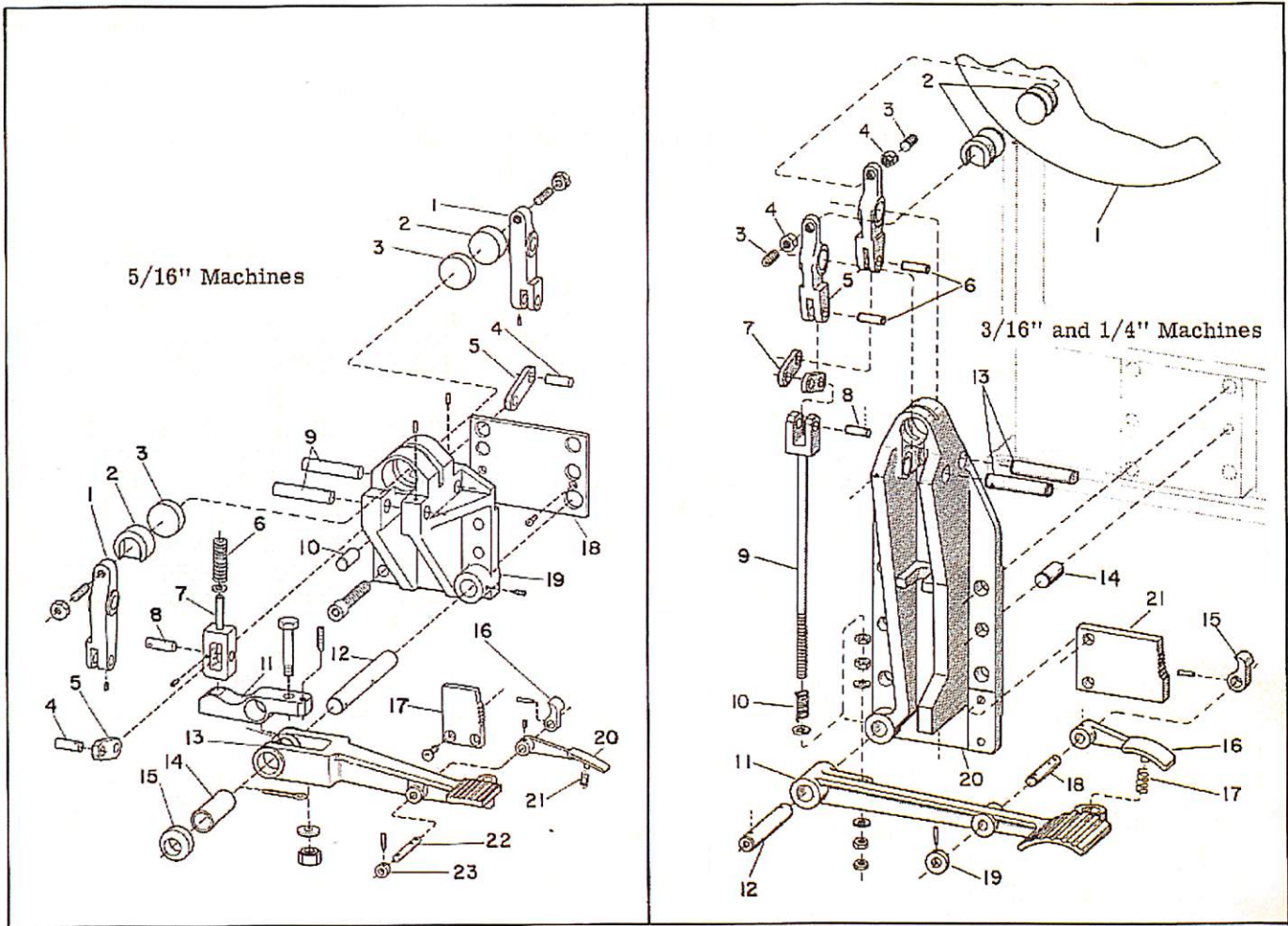

Figure 19

BRAKE

KEY NO.	PART NAME	QTY.	KEY NO.	PART NAME	QTY.
19-1	Toggle Arm	2	19-1	Brake - Disc	1
19-2	Disc Backing Plate	2	19-2	Brake Facing and Backing Plate	2
19-3	Disc	2	19-3	Brake Plate Set Screw	2
19-4	Toggle Arm Linkage Pin (Lower)	2	19-4	Hex Nut on Brake Toggle Arm	2
19-5	Toggle Arm Linkage	2	19-5	Brake Toggle Arm	2
19-6	Toggle Shoe Spring	1	19-6	Brake Toggle Arm Link Pin	2
19-7	Toggle Shoe	1	19-7	Brake Toggle Arm Linkage	2
19-8	Toggle Link Pin	1	19-8	Brake Connecting Rod Pin	1
19-9	Toggle Arm Pivot Pin (Upper)	2	19-9	Brake Connecting Rod	1
19-10	Dowel for Bracket to Bed	1	19-10	Brake Lever Return Spring	1
19-11	Operating Lever	1	19-11	Brake Lever	1
19-12	Treadle Pivot Pin	1	19-12	Brake Lever Pivot Pin	1
19-13	Treadle	1	19-13	Brake Toggle Arm Pivot Pin	2
19-14	Treadle Pivot Pin Sleeve	1	19-14	Dowel in Brake Housing	2
19-15	Treadle Pivot Pin Washer	1	19-15	Ratchet Pawl	1
19-16	Ratchet Pawl	1	19-16	Ratchet Release Lever	1
19-17	Ratchet Plate	1	19-17	Ratchet Operating Spring	1
19-18	Mounting Bracket Plate	1	19-18	Brake Ratchet Pivot Pin	1
19-19	Mounting Bracket	1	19-19	Collar on Brake Ratchet Pivot Pin	1
19-20	Ratchet Lever	1	19-20	Brake Housing	1
19-21	Ratchet Lever Spring	1	19-21	Ratchet Plate	1
19-22	Ratchet Lever Pin	1			
19-23	Collar for Ratchet Lever Pin	1			