

STOCK GAGE ADJUSTING ASSEMBLY

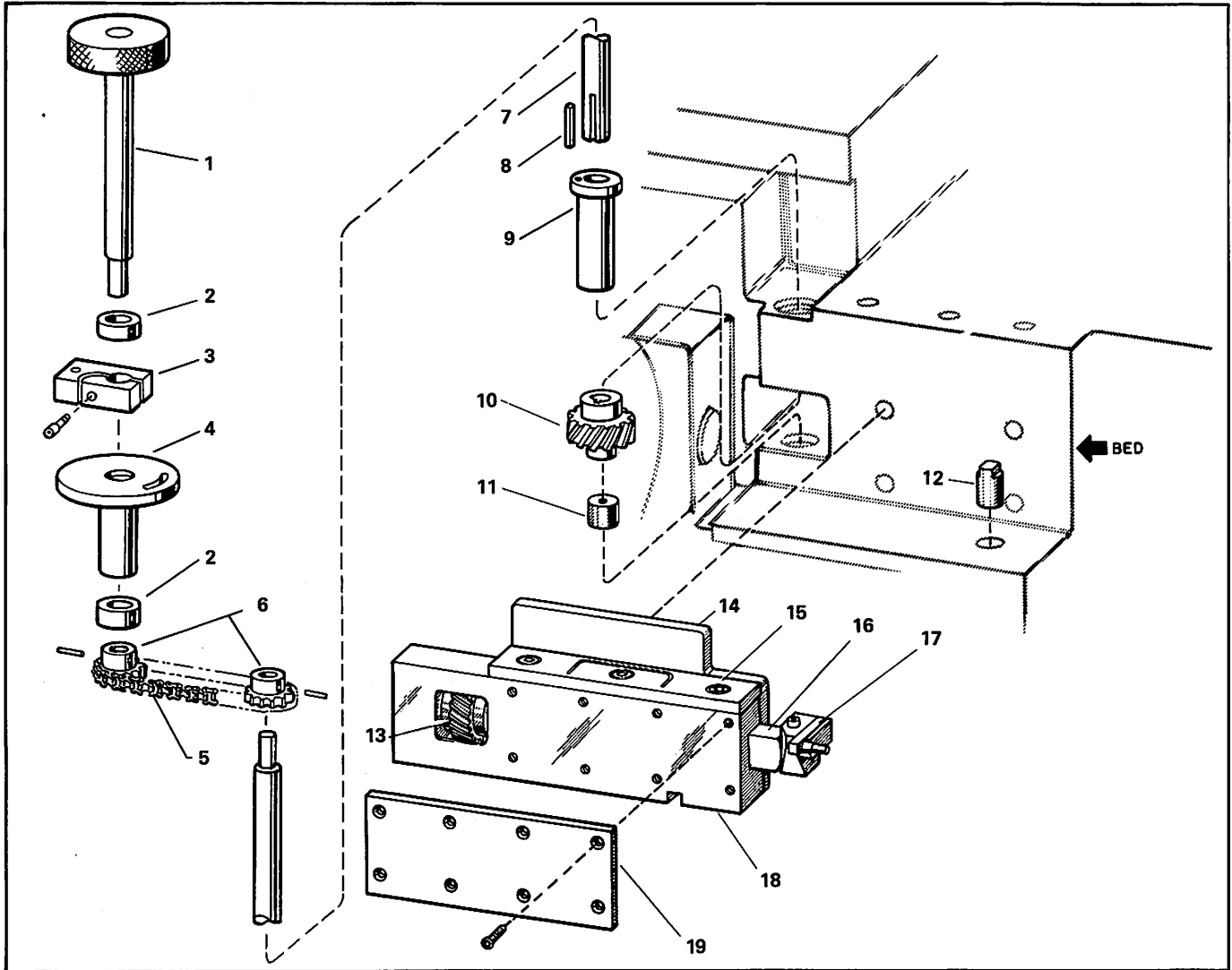

Figure SG

STOCK GAGE ADJUSTING ASSEMBLY

KEY NO.	PART NAME	QTY.	KEY NO.	PART NAME	QTY.
SG-1	Stock Gage Adjusting Shaft	1	SG-12	Dowel for Locating Adjustment Block	1
SG-2	Collar on Adjusting Shaft	2	SG-13	Stock Gage Adjustment Gear on Stem	1
SG-3	Clamp for Stock Gage Adjustment Shaft	1	SG-14	Adjustment Liner Wedge	1
SG-4	Stock Gage Shaft Housing	1	SG-15	Liner Under Heading Slide	1
SG-5	Stock Gage Adjusting Chain	1	SG-16	Stock Gage Stem	1
SG-6	Stock Gage Adjusting Sprocket	2	SG-17	Stock Gage Tip Short Work	1
SG-7	Stock Gage Sprocket Shaft	1		Long Work	1
SG-8	Key for Stock Gage Adjusting Gear on Shaft	1	SG-18	Adjustment Block for Heading Slide	1
SG-9	Adjustment Bush for Stock Gage Shaft	1	SG-19	Right Hand Side Heading Slide Liner	1
SG-10	Stock Gage Adjustment Gear on Shaft	1			
SG-11	Plug in Bed Under Stock Gage Gear	1			